

## Installation Guide - Heated Towel Rails

**Important!** Please read through these instructions carefully before installation. If you need assistance please call Faucet Strommen service team on **03 5450 4236**.

### Rough In

1. Mark the position of the heated rail and locate the centre point of the left side bracket (horizontal models) or the top bracket (vertical models). Note that heated towel rail must be more than 600mm above the floor.
2. Fit a timber noggin (2) in the frame wall on which to fasten the body (1). This should be installed square and plumb with the front face of the noggin being approx 50mm (max 61, min40) behind the front face of the finished wall surface. Remember to allow for plasterboard, tiles etc. (see diagram 2)
3. [Note that the aluminum spacer rail (4) is sold separately and is used to space multiple bodies in a row to create a ladder effect whilst keeping the bodies well aligned and nicely spaced. This is not needed for single heated rail mount and is useful, but not essential for multiple installation. If you are using a spacer rail, please contact us for install instructions.]
4. The body can now be screwed to the noggin using the screws provided. Orient the body with one of the conduit connection threads facing up so that the conduit (3) can be run up to the ceiling
5. Leave the thread protector boot on the brass thread of the inwall body as this is critical to protect the thread from damage during tiling etc.
6. Drill a 20mm hole through the plaster board and tiles to fit over the spigot.
7. On fit off, the cover can be sliced off at the finished wall level and the wires pulled through etc.

### Power Supply

8. The power supply runs off mains power and can power up to max 5 heated rails.
9. The power supply should be mounted not further than 2 meters from the furthest rail in a serviceable ventilated location that cannot get covered with insulation or debris.
10. The power supply comes with a standard 10amp plug and lead. **Electrician to ensure that the mains power supply is fitted with a timer.** Failure to fit a timer will void warranty. Max timer run time 3 hr.
11. A length of low voltage flex is supplied to link the power supply to the rails. Ensure this runs in a conduit.
12. Run the low voltage lead through the conduit and loop at each rough in body such that the loop protrudes 100mm from the threaded spigot.
13. Ensure that the transformer is powered off until fit off is complete.

### Fit Off

14. Ensure transformer power supply is off prior to fit off
15. Remove any loose debris or lumps of grout from around the threaded spigot and ensure the thread is clean.
16. Apply a small circular bead of silicone around the rear face of the adaptor (5) and screw this onto the threaded spigot until it is against the tile. Do not tighten as you may crack the tile, simply screw against the tile then wipe away excess silicone.
17. Measure and mark the position for the other side of the heated rail. (Note heated rails are normally supplied in 600 or 900mm centre to centre lengths, however custom lengths are available on request. Check the model and size of the rail you have.)
18. Drill and fasten the mount lug again applying silicone prior to screwing to the wall.
19. Electrician to connect the loose green plug supplied (6) to the low voltage supply wires.
20. Remove the heated rail from the package, place one of the dress rings/flanges onto the fitted bracket, then plug together the 2 green connectors.
21. Carefully feed the loose wire back into the bracket or wall spigot and bring the rail into place of the adaptor and fasten in place with the grub screw.
22. Locate the other bracket and press over the other end of the rail, attached the dress ring/flange and bring into place over the mount lug and fasten in place with a grub screw. Ensure the rail firmly fastened and secure.
23. Electrician to switch on the power supply and check heating operating and rail temperature is hot, but not too hot to touch.
24. Please report any faults prior to leaving site. See details below.

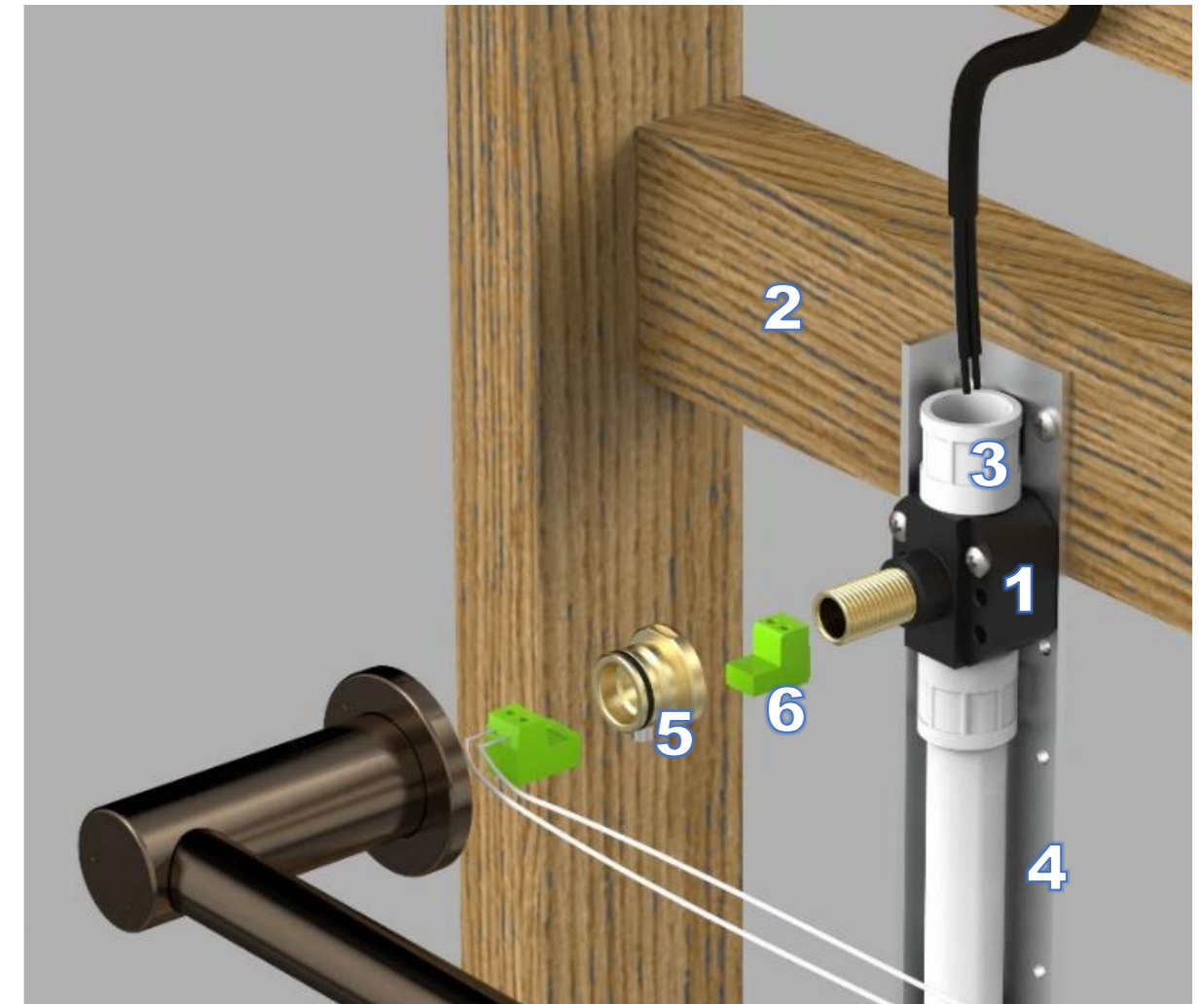

**Diagram 1**

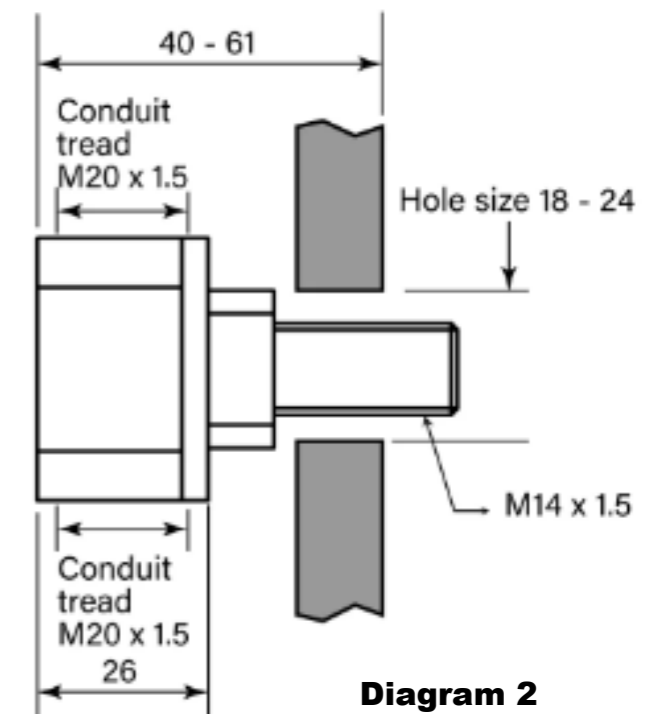

**Diagram 2**