

# Installation Guide

## Zero Hob Top Assembly

### Suits Models:

35306 35307 35308

### Important requirements:



Must be fitted in accordance with AS/NZS 3500 by qualified plumber

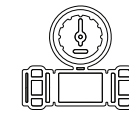

Mains 500kpa regulator must be fitted

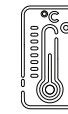

Maximum hot water temp. 65°C



Only clean municipal water supply. No bore, dam or hard water without filtration & treatment

### Cleaning

Clean only with a soft microfiber or similar cloth and warm clean water. Ensure that the cloth is clean and free of any grit or chemical. Dry tap off with a soft clean cloth. Ensure that your tap is not subject to any chemicals, building grit or any type of abrasive or polish. For care of special finishes please visit our website.

### Maintenance

Aerators may need to be flushed from time to time if flow diminishes or stream pattern deteriorates. For Pegasi & Cascade mixers, use the aerator key provided to unscrew the aerator. You will notice a "castle" pattern around the edge of the aerator, the key engages with this allowing you to unscrew the insert easily. For Zeos models, use the aerator key to unscrew the aerator housing, you will then be able to pop the insert out the top of the housing. Rinse off the upper face of the insert with running water and gently brush clean with an old toothbrush to remove any debris before refitting the aerator.

## Installation

1. This product is designed to be installed into a bench or sink of maximum thickness 32mm, and with hole cut-outs of  $\varnothing$  32 to 35 mm.

2. The product has been supplied partially assembled to keep installation time to a minimum.

3. Screw the octagonal brass nuts over the two valve bodies and place the body spacer over the assembly as shown.

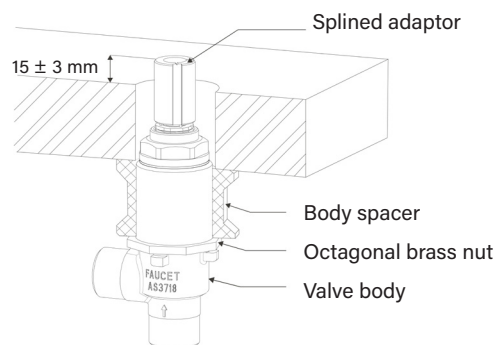

4. Push the Valve body assembly through from the underneath of the basin or sink so that the splined adaptor protrudes through the cut-out as shown above. Adjust the octagonal nut position so that the splined adaptor protrudes above the finished top surface by 15 +/-3mm. Do this for both valve body assemblies (Left and Right sides), Ensure the RED marking is on the left side, and the BLUE marking is on the right side.

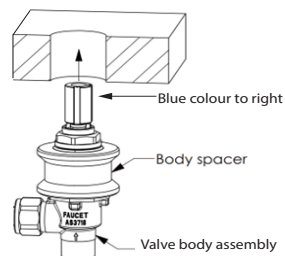
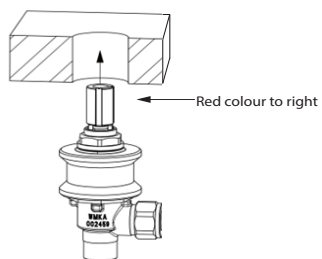

5. Lightly lubricate the O-rings on Tee-piece using water or an approved lubricant, then install the entire Valve assembly (including the two body spacers) into the bench or sink as shown.

6. While holding the valve assembly in place with the one hand, place the two RED Fibre washers onto the bench and screw the Brass flanges onto the locknut component of the Breech assembly. Lock gently into position using a large spanner. Then from the underside, tighten up the Octagonal Brass nuts firmly so that the breech is clamped securely onto the bench or sink.

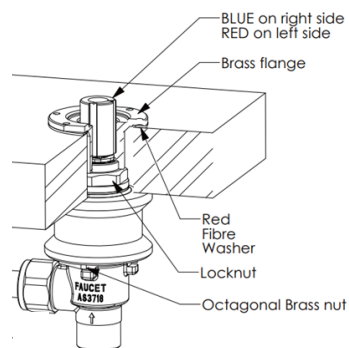

7. Place the Dress Rings over the Brass Flange as shown and align so that the H and C symbols are facing forward (H on the left-hand side and C on the right-hand side). Note that the dress ring has two 'C's – use the appropriate one which faces the correct way for hob installations. Loosely attach the Dress ring using the 3 Cap head screws provided.

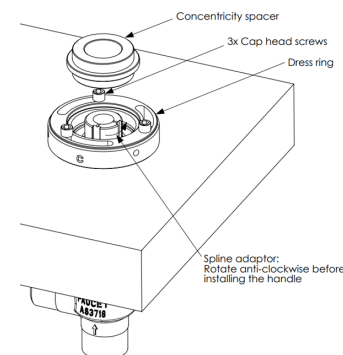

8. To ensure that the dress ring is perfectly concentric to the valve, we have supplied a round plastic concentricity spacer. Slide this over the splined adaptor and locate it into the dress ring, then lock up the 3 cap head screws.

9. Remove and discard the concentricity spacer.

10. Ensure the Splined adaptors are rotated anti-clockwise before assembling the handles.

11. Place the plastic slip rings over the step machined in the back of the handles, then assemble the handles (with slip rings) onto the tap with the wave form cut-away at the front. The handle has a pre-inserted grub screw that protrudes into the bore; the handle should slide over the splined adaptor with the grub screw engaging in one of the slots.

12. Rotate the handle clockwise through approximately 60 degrees until the waveform passes over the small fastening hole in the dress ring. Insert the Allen key through the hole and tighten the handle in place by fastening the grub screw onto the adaptor. Make sure the handle is pushed down firmly when tightening.

